

LED Lighting Fixtures

INSTALLATION INSTRUCTIONS

Read all instructions before installation.

DRY LOCATIONS ONLY

Cat. No. : **SAL-UWLED850M · SAL-UWLED1000M · SAL-UWLED1250M · SAL-UWLED1500M** (120-277Volts)

SPECIFICATION

Section

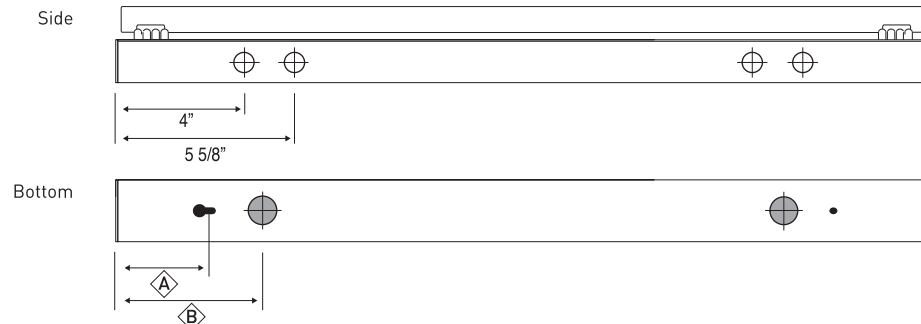
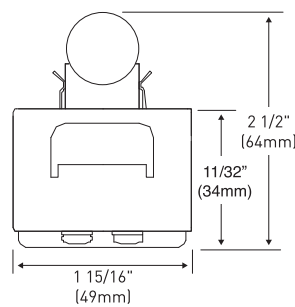

- 7/8" K.O.
- ⊕ 10/16" K.O.
- 3/16" Mounting Hole
- 3/16" × 1/4" Mounting Hole

| Length | Mounting Hole Spacing | Mounting Hole Diameter |
|--------|-----------------------|------------------------|
| 34" | 3" | 4 9/16" |
| 40" | 5 15/16" | 8 5/16" |
| 50" | 8 7/8" | 10 7/16" |
| 60" | 14 13/16" | 15 3/8" |

| voltage | catalog no. | O.A.length | Input current (A) | Input wattage (W) | Weight (lb) | Lamp type | Lamp wattage (W) | Lumen (lm) @5000K |
|---------|--|-------------------|-------------------|-------------------|-------------|------------|------------------|-------------------|
| 120-277 | <input type="checkbox"/> SAL-UWLED 850M | 33 1/2" (850 mm) | 0.13-0.07 | 16 | 2.2 | SLED-U 850 | 12.7 | 1230 |
| | <input type="checkbox"/> SAL-UW LED 1000 M | 39 3/8" (1000mm) | 0.16-0.08 | 19 | 2.4 | SLED-U1000 | 14.6 | 1450 |
| | <input type="checkbox"/> SAL-UW LED 1250 M | 49 1/4" (1250mm) | 0.19-0.09 | 23 | 2.6 | SLED-U1250 | 18.4 | 1870 |
| | <input type="checkbox"/> SAL-UW LED 1500 M | 59 1/16" (1500mm) | 0.23-0.11 | 28 | 3.0 | SLED-U1500 | 21.6 | 2190 |

WIRING DIAGRAM for dimming

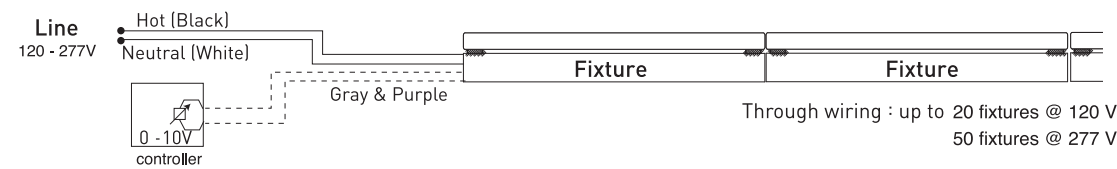

CAUTION to prevent short lamp life, LED driver, bad replacement

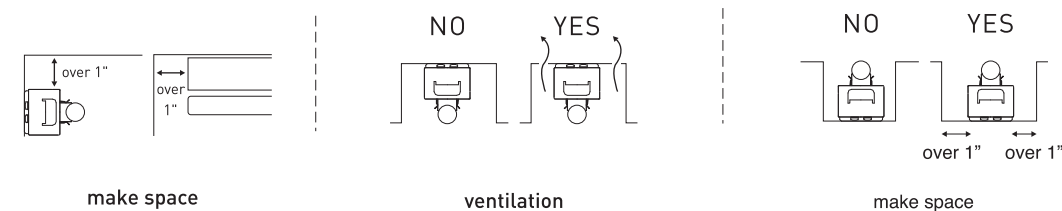

This device complies with part 15 of the FCC Rules. Operation is subject to the following two conditions:

- (1) This device may not cause harmful interference, and
- (2) this device must accept any interference received, including interference that may cause undesired operation.

Sales office
Verbatim Americas, LLC
 1200 West WT Harris Blvd. Charlotte, NC 28262
 Toll Free : 877-NIPPO-11 (647-7611)
 e-mail : nippo@verbatim.com

MANUFACTURER
DN LIGHTING CO., LTD.
 15-23 Miyamatsu-cho, Hiratsuka,
 Kanagawa, 254-0036, JAPAN

INSTALLATION

WARNING : To avoid fire, electric shock or death
TURN OFF POWER at circuit breaker or fuse

Step 1 remove HOUSING COVER by unscrewing and twisting

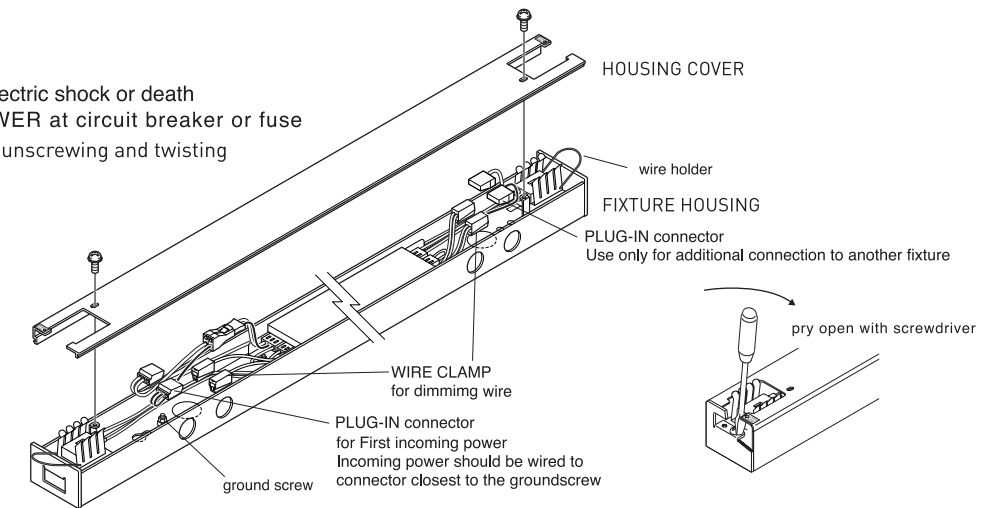

Step 2 knock out KNOCKOUT plate at the bottom or side

bottom/back - feed

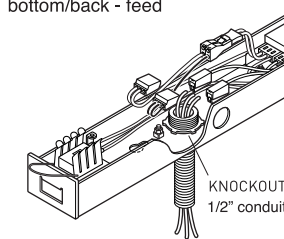

side - feed

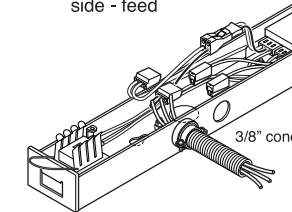

for end feed, use POWER FEED BOX (not included)

SF POWER FEED BOX (not included)

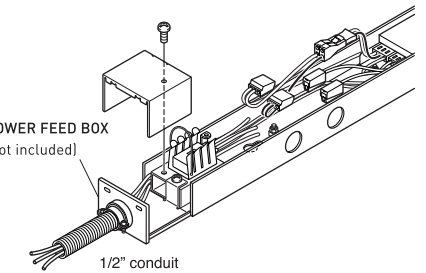

Step 3 mount FIXTURE HOUSING by using SCREW HOLES at the bottom

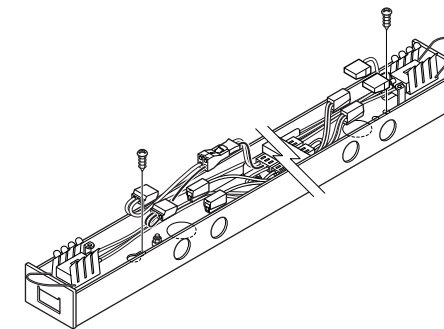

For connecting each fixture, remove the end plate and use I-coupling connector.

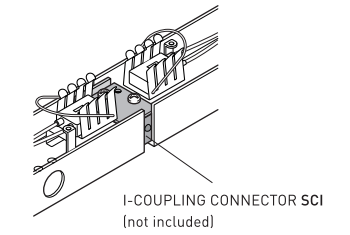
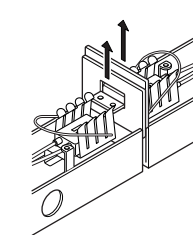

Step 4 wire according to N.E.C. and any applicable local codes

Remove 7/16" (11mm) of insulation from power supply wire and insert to PLUG-IN connector

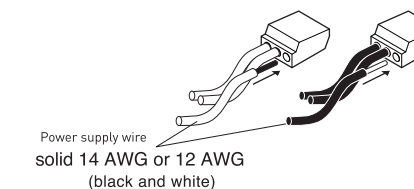

Remove 1" (25mm) of insulation from grounding wire and place onto the grounding post

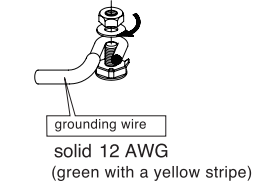

in case of dimming fixture
 Remove 7/16" (11mm) of insulation from dimming control wire and insert to wire Clamp

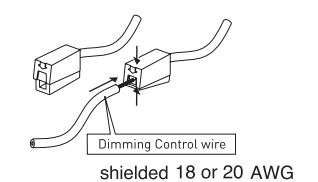

Step 5 attach HOUSING COVER and tighten screws

Step 6 Insert the LED lamp properly into the lamp holder to the black line till unseen

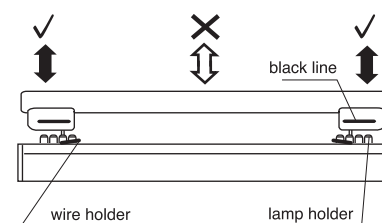

Condition of Lamp-installation

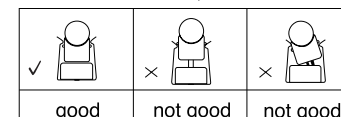

in case of installing downward, use wire holder for safety

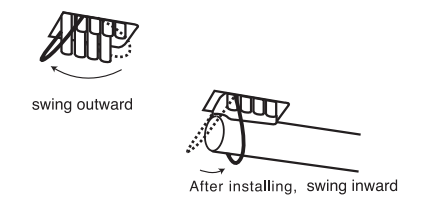

Step 7 Restore Power at circuit breaker or fuse.
Installation is complete.

WARNING :
 When replacing the LED driver, DISCONNECT the connector.

INSTRUCTIONS D'INSTALLATION

Lisez toutes les instructions avant l'installation. POUR EMPLACEMENTS SECS SEULEMENT

Cat. No. : SAL-UWLED850M · SAL-UWLED1000M · SAL-UWLED1250M · SAL-UWLED1500M (120-277Volts)

SPÉCIFICATIONS

section

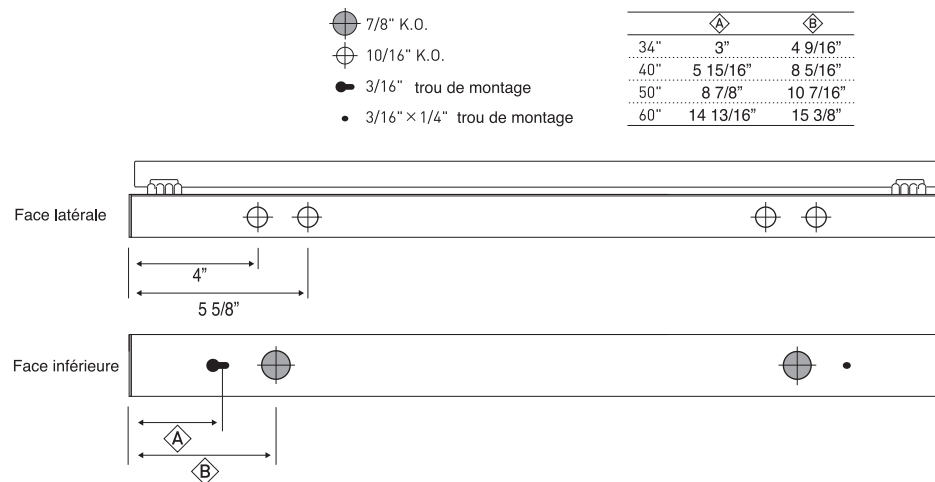
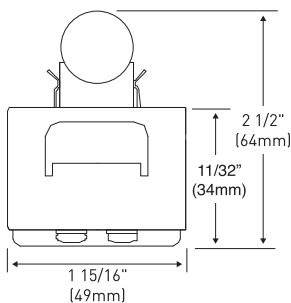

| tension | no de catalogue | longueur | Courant d'entrée (A) | Puissance d'entrée (W) | poids (lb) | Lampe type | puissance de la lampe (W) | Lumen (lm) @5000K |
|---------|---------------------|-------------------|----------------------|------------------------|-------------|------------|---------------------------|-------------------|
| 120-277 | □ SAL-UWLED 850M | 33 1/2" (850 mm) | 0.13-0.07 | 16 | 2.2 | SLED-U 850 | 12.7 | 1230 |
| | □ SAL-UW LED 1000 M | 39 3/8" (1000mm) | 0.16-0.08 | 19 | 2.4 | SLED-U1000 | 14.6 | 1450 |
| | □ SAL-UW LED 1250 M | 49 1/4" (1250mm) | 0.19-0.09 | 23 | 2.6 | SLED-U1250 | 18.4 | 1870 |
| | □ SAL-UW LED 1500 M | 59 1/16" (1500mm) | 0.23-0.11 | 28 | 3.0 | SLED-U1500 | 21.6 | 2190 |

SCHÉMA DE CABLAGE pour la gradation

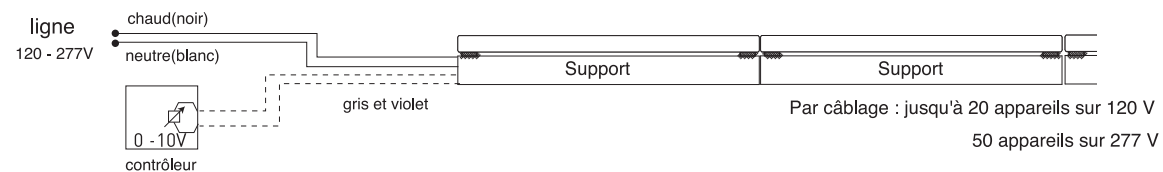

ATTENTION pour préserver la durée de vie des lampes et du driver ou éviter un mauvais placement

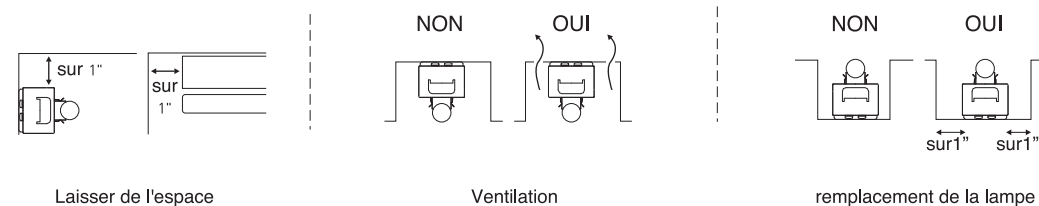

Bureaux
Verbatim Americas, LLC
1200 West WT Harris Blvd. Charlotte, NC 28262, USA
Numéro vert (US)+1 877-NIPPO-11(647-7611)
e-mail : nippo@verbatim.com

Fabricant
DN LIGHTING CO., LTD.
15-23 Miyamatsu-cho, Hiratsuka,
Kanagawa, 254-0036, JAPAN

INSTALLATION

DANGER : pour éviter un incendie ou une décharge électrique potentiellement mortelle, COUPER LE COURANT ÉLECTRIQUE sur la tableau à fusibles

Etape 1 Ôter le couvercle du boîtier en dévissant les fixations.

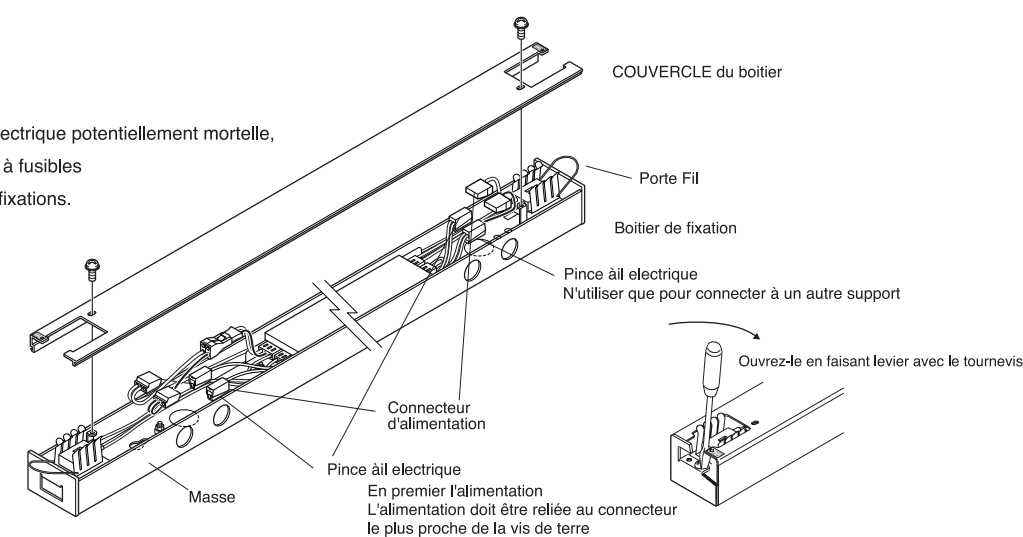

Etape 2 Retirer la plaque amovible sur la face inférieure ou latérale

Alimentation par dessous

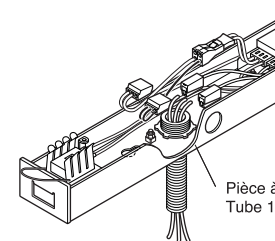

Alimentation latérale

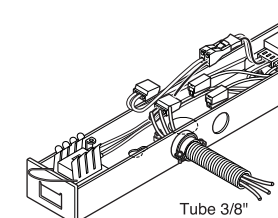

Pour une alimentation par le côté, utilisez un POWER FEED BOX (non fourni)

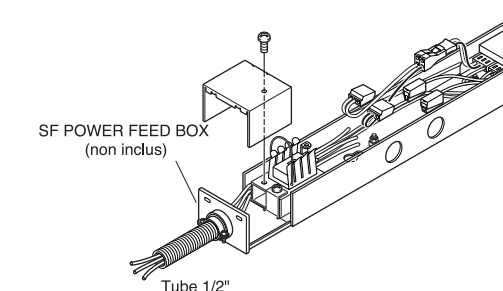

Etape 3 Fixer le boîtier avec des vis en utilisant les trous prévus à cet effet

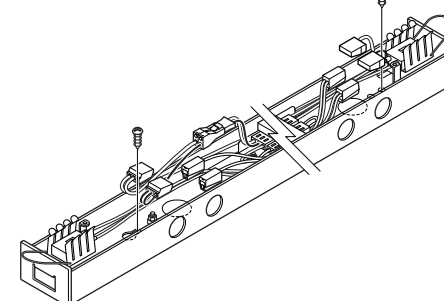

Pour connecter chaque support, enlever l'embout et utiliser un connecteur de couplage I-

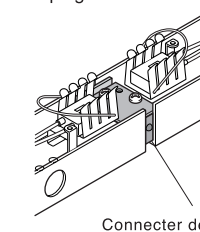
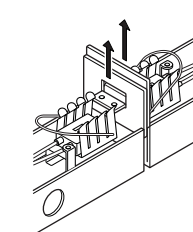

Etape 4 Câblage selon norme N.E.C ou tout autre norme locale applicable

Retirer 7/16" (11mm) d'isolant du fil d'alimentation et insérer dans les prises de connection

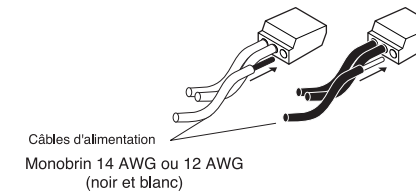

Retirer 1" (25mm) d'isolant du fil de masse et fixer sur la masse

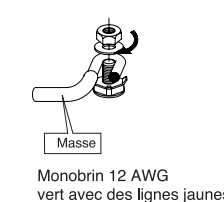

Dans le cas d'une utilisation sur dimmer, retirer 7/16" (11mm) d'isolant du câble de contrôle du dimmer et insérer dans la griffe.

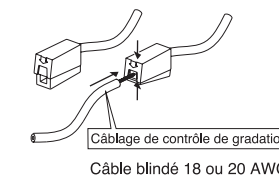

Etape 5 Fixer le couvercle en serrant les vis

Etape 6 Insérer la lampe correctement dans son support jusqu'à ne plus voir la ligne noire

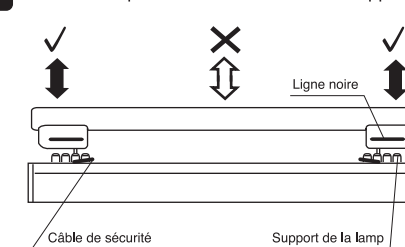

| | | |
|-----|---------|---------|
| ✓ | × | × |
| Bon | Mauvais | Mauvais |

Dans le cas d'une installation à l'envers, utilisez le câble de sécurité



Avertissement :
lors du remplacement du pilote LED débranchez le connecteur.

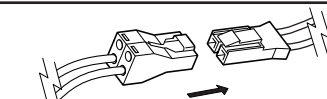

Etape 7 Rétablir le courant sur le boîtier fusible

L'installation est terminée